

## 3/2-way cam valve insert

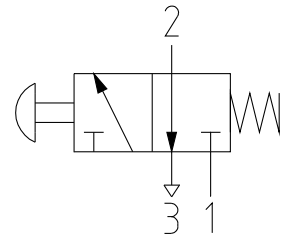
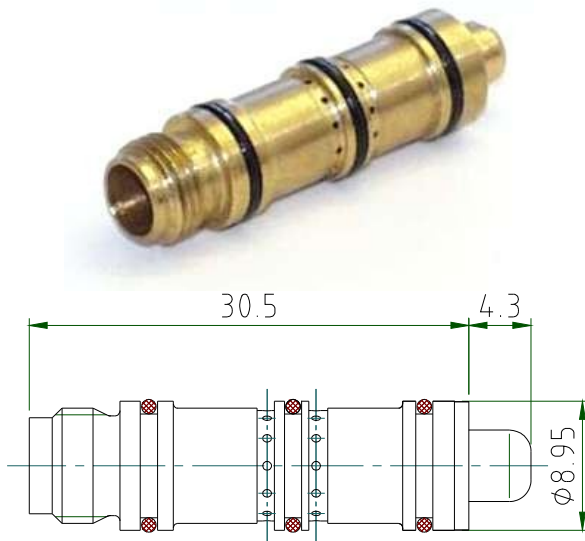
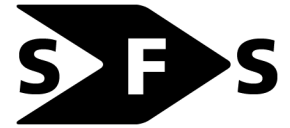

### Special feature:

The valve insert is screwed into a bore and the connections are sealed with O-rings. The valve insert solution allows the valves to be changed quickly.

### Applications:

Textile machinery

SPECIFICATION	
general	
design	spool valve
actuation	cam
return	pneumatic, spring
connection	valve insert screwed into a bore; connections sealed with O-rings
ambient temperature	-20°C to +60°C
medium temperature	-20°C to +60°C
material	body and spool: brass seals: perbunan (NBR)
mounting method	M8x0.75 thread
mounting position	any
scope of delivery	valve insert, return spring
weight	11 g
pneumatic	
configuration	3/2-way NC
flow medium	filtered, lubricated or unlubricated compressed air
operating pressure range	2.5 bar to 8 bar
nominal size	DN 2 mm