

2-Finger Scissors Gripper

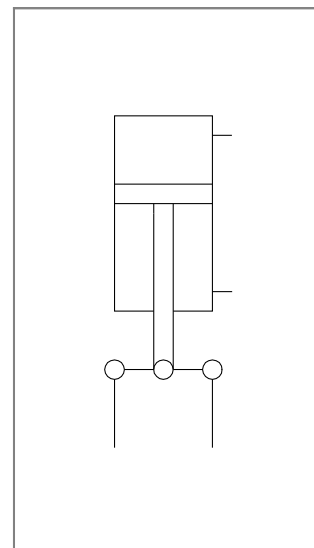
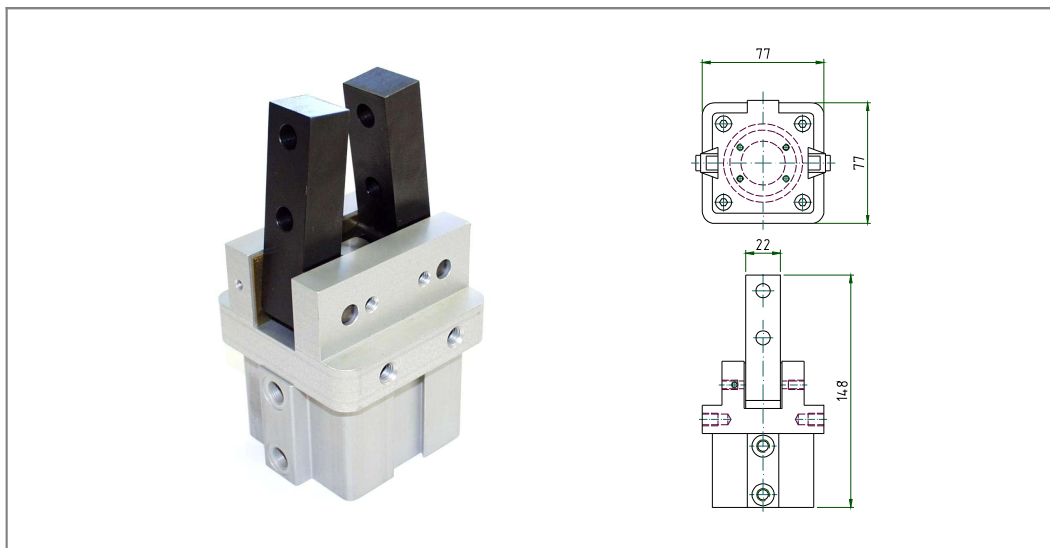

Special feature:

Short, rugged design with integral sensor; sensor available with standard pneumatic solenoid switches

Application:

Welding equipment used in the manufacture of welded mesh panels; other general applications also possible

SPECIFICATION	
general	
design	2-finger scissors gripper, pneumatic, double-acting
piston diameter	50 mm
opening angle of gripper fingers	25°
closing angle of gripper fingers	-12°
connection	G1/8 internal thread
ambient temperature	-20°C to +80°C
medium temperature	-20°C to +80°C
material	housing anodized aluminum; gripper fingers browned steel; piston rod stainless steel, guides brass; bolts zinc-plated steel; seals perbunan (NBR)
end stop damper	no
mounting method	M8 thread in the housing
mounting position	any
magnetic scanning	standard
weight	1.56 kg
pneumatic	
control medium	filtered, lubricated or unlubricated compressed air
operating pressure range	1.5 to 8 bar