

Mini pressure reducer

type MRW0. , size M5, without secondary exhaust

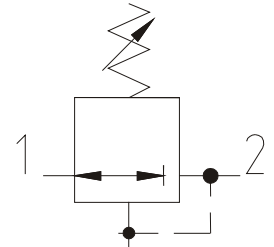
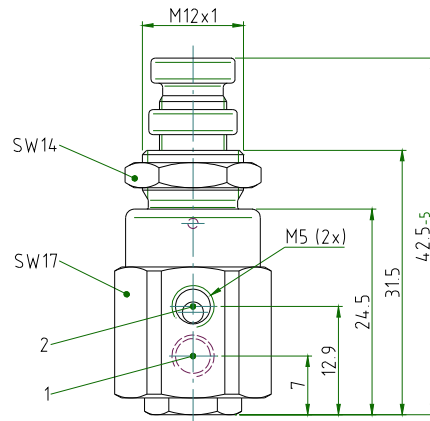

SPECIFICATION	
general	
construction	piston type without secondary exhaust
connection	thread M5
ambient temperature	-20°C to +60°C
fluid temperature	-20°C to +80°C
material	metal parts: brass (Ms58) nickel-plated seals: perbunan (NBR) springs: stainless steel nut: brass (Ms58) nickel-plated
mounting	panel mounting nut
installation position	any position
items supplied	reducer and panel mounting nut
fluid	filtered (100 µm), neutral gases and liquids
inlet pressure	max. 10 bar at MRW0-8, max. 6 bar at MRW0-2
outlet pressure	MRW0-2: 0.2 – 2 bar, MRW0-8: 1 – 8 bar
flow rate	k_{vs} -value: 0.093 m ³ /h (1,55 l/min) water
nominal diameter	DN 2.5 mm

type	article-nr.	outlet pressure (bar)	seal material	weight (approx. g)
MRW0-2	90 000 366	0.2 – 2	NBR	46
MRW0-8	90 000 367	1 – 8	NBR	46